



Parts List
6" AAT-35 and AAT-57
Auto-Adjust® II Turbo-Meters

Parts List
6" AAT-35 and AAT-57
Auto-Adjust® II Turbo-Meters

Working Pressures:
175, 275, 720, 1440 psi

6" AAT-35 and AAT-57 AUTO-ADJUST® II TURBO-METER

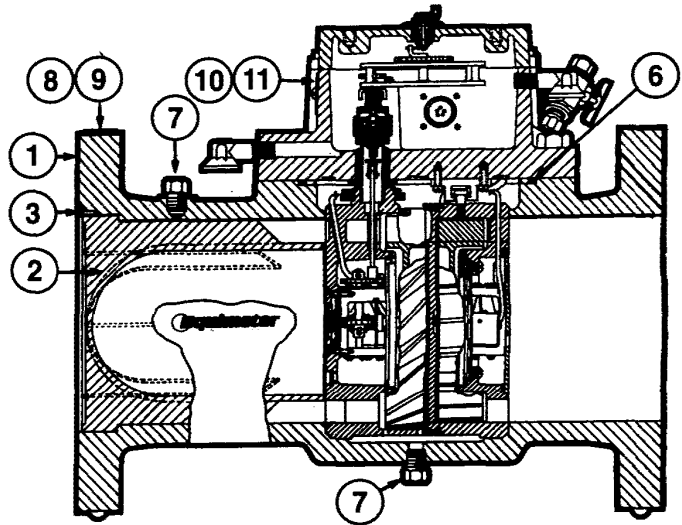
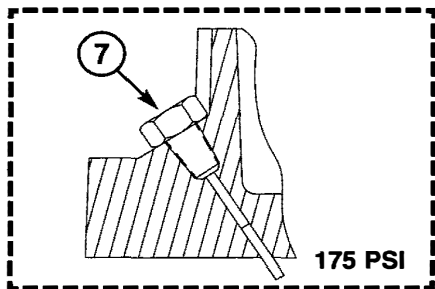
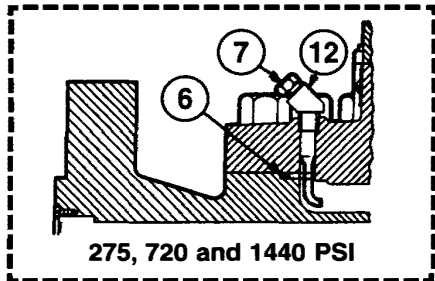

**GENERAL ASSEMBLY AAT-35 AND AAT-57
AUTO-ADJUST® II TURBO-METER**

Body Assembly Components

ILLUSTRATION NUMBER	QUANTITY REQUIRED	PART DESCRIPTION	PART NUMBER	
1	1	Main Body Assembly, Aluminum, 175# W.P., With Badges Less Nose Cone	006-24-611-20	
		Main Body Assembly, Cast Steel, 275# W.P., ANSI 150, With Badges Less Nose Cone	006-24-611-21	
		Main Body Assembly, Cast Steel, 720# W.P., ANSI 300, With Badges Less Nose Cone	006-24-611-60	
		Main Body Assembly, Cast Steel, 1440# W.P., ANSI 600, With Badges Less Nose Cone	006-24-611-90	
		Main Body Assembly, Cast Steel, 1440# W.P., ANSI 600, With Badges Less Nose Cone With Ring Joint Flanges	006-24-611-91	
2	1	Nose Cone With Straightening Vanes, 175# W.P.	006-24-305-21	
		Nose Cone With Straightening Vanes, 275#, 720#, 1440# W.P.	006-24-305-91	
3	3	#8-32 x 3/8" Long Machine Screw, Truss Head, Stainless Steel	950426	
4	1	Manufacturer Nameplate, 175# W.P. (Not Shown)	AAT-35	006-24-073-20-555
			AAT-57	006-44-073-20-555
		Manufacturer Nameplate, 275# W.P. (Not Shown)	AAT-35	006-24-073-30-555
			AAT-57	006-44-073-30-555
		Manufacturer Nameplate, 720# W.P. (Not Shown)	AAT-35	006-24-073-60-555
			AAT-57	006-44-073-40-555
Manufacturer Nameplate, 1440# W.P. (Not Shown)	AAT-35	006-24-073-90-555		
	AAT-57	006-44-073-50-555		
5	4	Manufacturer Nameplate Drive Screws, #4 x 3/16" Long Round Head Brass Drive Screw	903004	
6	1	Top Plate to Body "O" Ring, 175# W.P., Buna	934346	
		Top Plate to Body "O" Ring, 175# W.P., Viton-A (Optional)	906743	
		Top Plate to Body "O" Ring, 275#, 720#, 1440# W.P., Buna	950190	
		Top Plate to Body "O" Ring, 275#, 720#, 1440# W.P., Viton (Optional)	906744	
7	AR	1/2"-18 Steel Pipe Plug	906055	
8	1	Inlet Badge (On Inlet Flange of Body)	015-16-090-02	
9	2	Inlet Badge Drive Screw, #2 x 1/8" Round Head Brass	903003	
10	1	Pulse Factor Badge (On Top Plate) FT ³	006-32-073-10	
		Pulse Factor Badge (On Top Plate) M ³	006-32-073-11	
11	2	#8-32 x 1/4" Long Round Head Brass Machine Screw	903055	
12	1	45° Steel Elbow 1/4" Male to Female for 275#, 720# and 1440#	950762	
13	1	Internal Mechanism Badge (Not Shown)	AAT-35	006-34-073-02
			AAT-57	006-44-073-02-555
14	4	#0 x 1/8" Long Drive Screw (Not Shown)	903001	
15	1	C.S.A. Manufacturer Nameplate (Not Shown)	006-32-074-00	
16	4	Drive Screw for C.S.A. Nameplate (Not Shown)	903003	

*Recommended Spare Parts

INDEX PLATE ASSEMBLY

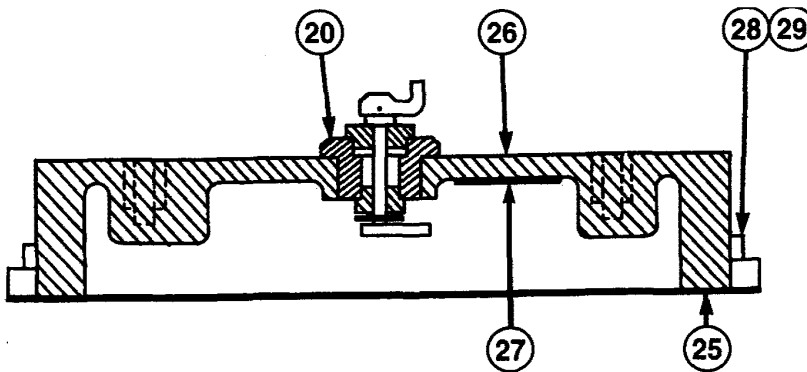

INDEX SHAFT AND GLAND ASSEMBLY

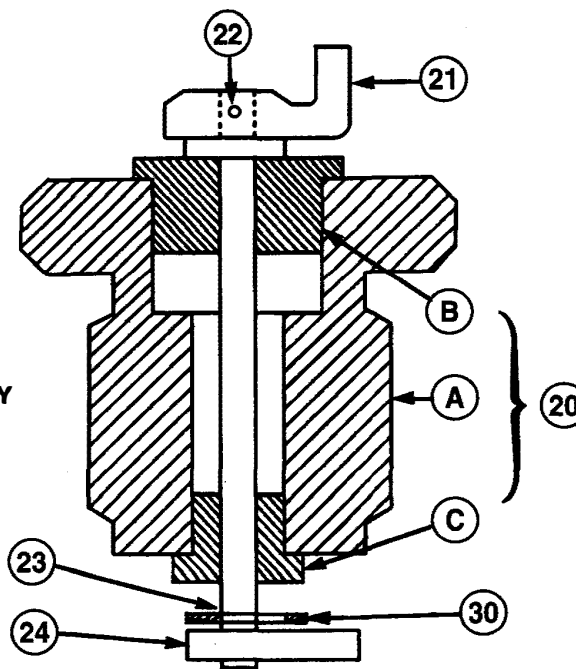

Index Plate Assembly Components

ILLUSTRATION NUMBER	QUANTITY REQUIRED	PART DESCRIPTION	PART NUMBER
20	1	Index Shaft Gland Assembly (Includes Illustration Nos. 20A-C)	006-24-323-00
20A	1	Gland	006-24-023-00
20B	1	Bushing (Top)	006-24-052-01
20C	1	Bushing (Bottom)	001-60-052-62
21	1	Top Index Shaft Dog	006-24-061-04
*22	1	Shear Pin, Top Index Shaft Dog	006-24-056-00
23	1	Index Shaft	006-24-054-02
24	1	Bottom Index Shaft Dog	006-24-071-00
*25	1	Gasket, Index Plate to Top Plate	006-24-160-03
26	1	Index Plate	006-24-004-21
27	1	Wiring Label	006-32-105-00
28	3	Cap Screw, Index Plate to Top Plate, $\frac{5}{16}$ "-18 x $\frac{3}{4}$ " Hexagonal Head Steel	910028
29	1	Seal Cap Screw, Index Plate to Top Plate, $\frac{5}{16}$ "-18 x $\frac{3}{4}$ " Hexagonal Head Steel	002-65-057-02
30	1	Retaining Ring	950578

*Recommended Spare Parts

6" AAT-35 and AAT-57 AUTO-ADJUST® II TURBO-METER

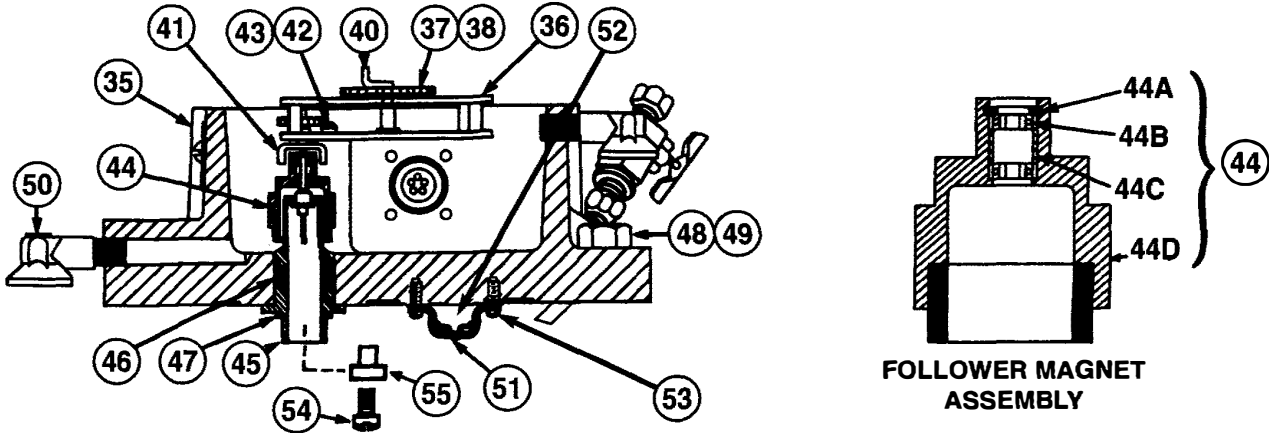

Top Plate Assembly – Mechanical Components

ILLUSTRATION NUMBER	QUANTITY REQUIRED	PART DESCRIPTION	PART NUMBER
35	1	Top Plate Assembly, Aluminum, 175# W.P.	006-34-303-20
		Top Plate Assembly, Cast Steel, 275# W.P.	006-34-303-31
		Top Plate Assembly, Cast Steel, 720# W.P.	006-34-303-91
		Top Plate Assembly, Cast Steel, 1440# W.P.	006-34-303-91
36	1	Intermediate Gear Assembly, 100 CF/Rev., Less Change Gears	006-34-212-40
		Intermediate Gear Assembly, 10 M ³ /Rev., Less Change Gears	006-34-212-00
37	1	Large Change Gear (Note: "XX" Refers to Gear Blank (Diameter) Size, "YY" Refers to Number of Gear Teeth. Digits Must Be Substituted for "XX" and "YY" When Ordering)	006-24-3XX-YY
38	1	Small Change Gear (See Note for Illustration No. 37 Above)	006-24-3XX-YY
39	1	Small Change Gear Nut, #4-40 Hex Stainless Steel (Not Shown)	907639
40	1	Intermediate Gear Output Dog (Top)	002-66-071-03
41	1	Intermediate Gear Input Dog (Bottom)	006-24-061-20
42	3	Intermediate Gear Retaining Screws, #8-32 x 3/8" Long Fillister Head Steel	903371
43	3	#8 External Lockwasher, Stainless Steel	950371
*44	1	Follower Magnet Assembly (Includes Illustration Nos. 44 A-D)	006-24-313-20
*44A	1	Retaining Ring	904691
*44B	2	Bearing	905462
44C	1	Spacer	006-24-106-20
44D	1	Follower Magnet Holder Assembly With Magnet	006-24-213-20
*45	1	Driver Magnet Well and Post Assembly, 175# W.P. (Includes Illustration No. 46)	006-24-244-20
		Driver Magnet Well and Post Assembly, 1440# W.P. (Includes Illustration No. 46)	006-24-244-90
*46	1	Driver Magnet Well "O" Ring, Buna	950193
		Driver Magnet Well "O" Ring, Viton (Optional)	908264
*47	1	Driver Magnet Well Seal, Buna	904214
		Driver Magnet Well Seal, Viton	906736
48	7	Cap Screw, Top Plate to Body, 175# W.P., 1/2"-13 x 1 1/2" Long Hex Head Steel Gr. 5	910107
		Cap Screw, Top Plate to Body, 275# W.P., 1/2"-13 x 1 3/8" Long Hex Head Steel Gr. 8	935647
		Cap Screw, Top Plate to Body, 720# and 1440# W.P., 3/4"-10 x 2 1/2" Long Hex Head Steel Gr. 8	935680
49	1	Seal Cap Screw, Top Plate to Body, 175# W.P., 1/2"-13 x 1 1/2" Long Hex Head Steel Gr. 5	006-24-056-01
		Seal Cap Screw, Top Plate to Body, 275# W.P., 1/2"-13 x 1 3/8" Long Hex Steel Gr. 8	006-24-056-02
		Seal Cap Screw, Top Plate to Body, 720# and 1440# W.P., 3/4"-10 x 2 1/2" Long Hex Head Steel Gr. 8	006-24-057-91
50	2	Vent Cap 1/4"	006-24-505-01
51	1	Extractor Bracket	006-34-089-01
52	1	Extractor Bracket Spring Clip	006-41-089-00
53	2	Extractor Bracket Retainer Screws, #8-32 x 3/8" Long Fillister Head Machine Screw, Stainless Steel	903371
54	2	Adapter Plate Screw, #8-32 x 7/8" Long Fillister Head	906847
55	2	Adapter Plate Bushing	006-32-113-01

*Recommended Spare Parts

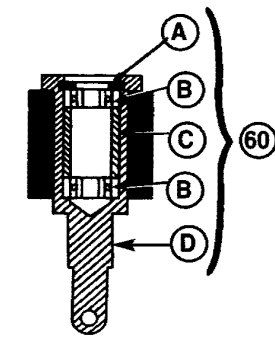

**DRIVER
MAGNET
HOLDER AND
BEARING
ASSEMBLY**

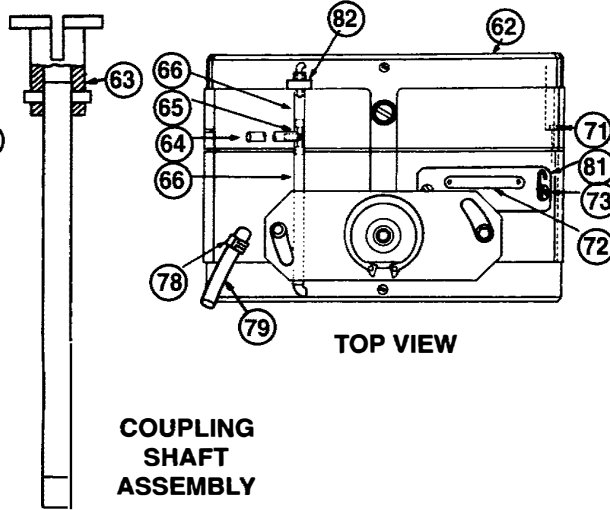

**COUPLING
SHAFT
ASSEMBLY**

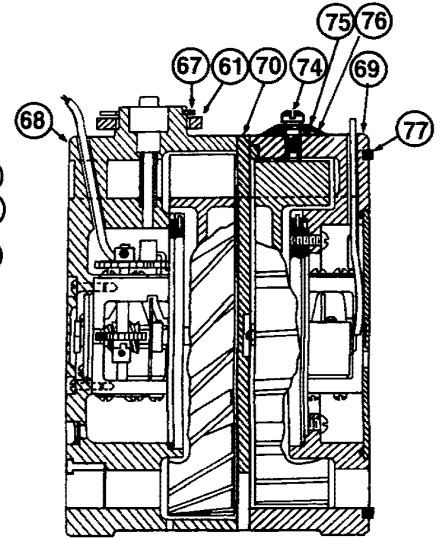

SIDE VIEW

Internal Housing Assembly – Mechanical Components

ILLUSTRATION NUMBER	QUANTITY REQUIRED	PART DESCRIPTION	PART NUMBER
*60	1	Driver Magnet Holder and Bearing Assembly (Includes Illustration Nos. 60A-D)	006-31-334-00
60A	1	Bearing Retaining Ring	904691
*60B	2	Bearing	905462
60C	1	Spacer	006-22-106-03
60D	1	Driver Magnet and Pin Assembly	006-31-234-02
61	1	Adapter Plate	006-32-062-01
62	1	Internal Housing Assembly, Calibrated W/Change Gears, 175# W.P., CuFt	AAT-35 006-34-302-01
		Internal Housing Assembly, Calibrated W/Change Gears, 175# W.P., Metric	AAT-35 006-34-302-02
		Internal Housing Assembly, Calibrated W/Change Gears, High Pressure, CuFt	AAT-35 006-34-302-90
		Internal Housing Assembly, Calibrated W/Change Gears, High Pressure, Metric	AAT-35 006-34-302-91
		Internal Housing Assembly, Calibrated W/Change Gears, 175# W.P., CuFt	AAT-57 006-44-302-01
		Internal Housing Assembly, Calibrated W/Change Gears, 175# W.P., Metric	AAT-57 006-44-302-02
		Internal Housing Assembly, Calibrated W/Change Gears, High Pressure, CuFt	AAT-57 006-44-302-90
		Internal Housing Assembly, Calibrated W/Change Gears, High Pressure, Metric	AAT-57 006-44-302-91
63	1	Coupling Shaft Assembly, 175# and 275# W.P.	006-34-345-00
		Coupling Shaft Assembly, 720# and 1440# W.P.	006-34-345-90
64	1	Tubing, Top Plate to Internal Housing	99993
65	1	Tee, 1/8" Polypropylene	950247
66	1	Tubing	99993
67	1	Retaining Ring	904435
**68	1	Main (Metering) Rotor Assembly	AAT-35 006-34-550-02
			AAT-57 006-44-550-02
**69	1	Sensor Rotor Assembly	AAT-35 006-34-550-03
			AAT-57 006-44-550-03
**70	1	Center Plate	AAT-35 006-34-109-02
			AAT-57 006-44-109-02
71	2	Module Connecting Screw, #6-32 x 1/8" Long Stainless Steel Machine Screw Note: Maximum Torque = 10 Inch/lb.	950397
72	1	Serial Number Badge	006-34-073-01
73	2	Serial Number Retaining Screw, #4-40 x 1/4" Long Pan Head Stainless Steel Machine Screw	950380
74	1	Shoulder Screw, 1/4" x 1/4" Stainless Steel	950319
75	1	"O" Ring, Buna	934005
		"O" Ring, Viton	904839
76	1	Disc Spring	950749
77	1	Module To Body Seal, Buna	950709
78	2	Compression Ring (Pressure Tubing), AAT-35 Only	950772
79	1	.5" Pressure Tubing, AAT-35 Only	800700
81	1	Clip for Wires	950517
82	3	Compression Ring (Lube Tubing)	950682
83	1	Retrofit Adapter Kit (Not Shown)	006-32-190-00
84	1	Oil Tube Replacement Assembly (Not Shown) (Includes 64, 65, 66 & 82)	006-34-325-00

*Recommended Spare Parts

**Illustration Nos. 68, 69, and 70 affect calibration. These components must be ordered in combination and cannot be supplied as separate items.

6" AAT-35 and AAT-57 AUTO-ADJUST® II TURBO-METER

MAIN (METERING) ROTOR ASSEMBLY COMPONENTS

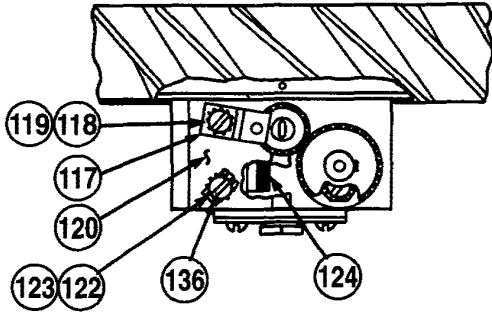

TOP VIEW BEARING BRACKET

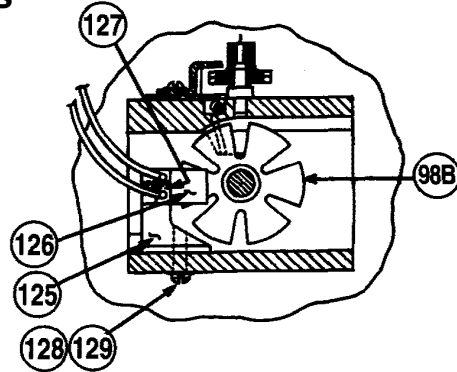

SECTION VIEW BEARING BRACKET

WORM AND CHOPPER ASSEMBLY

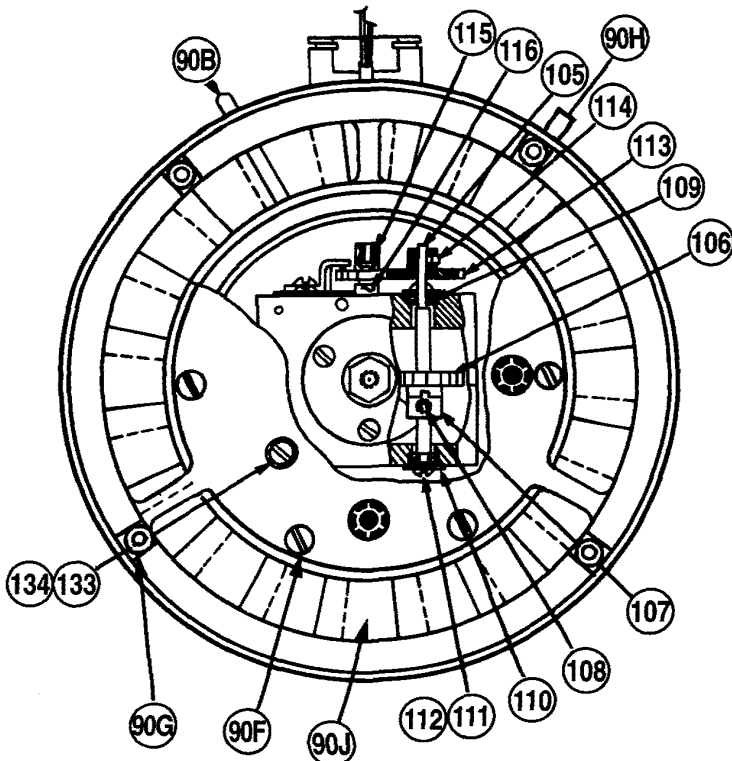
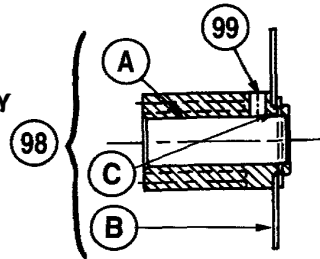

INLET VIEW

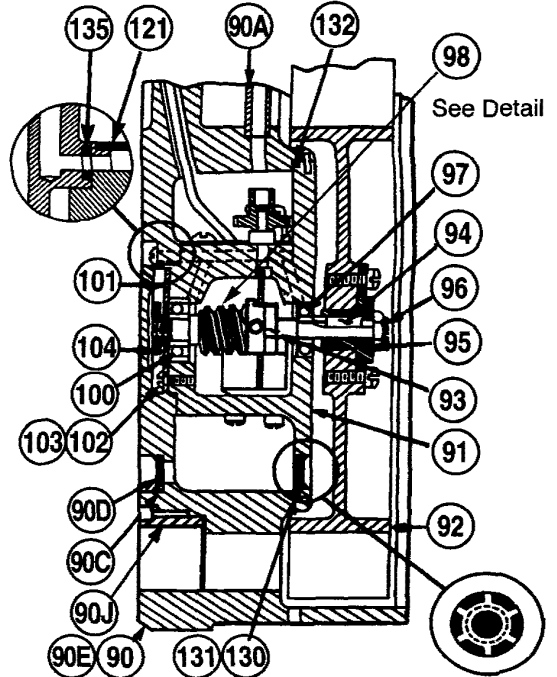

SIDE VIEW



Main (Metering) Rotor Assembly Components

ILLUSTRATION NUMBER	QUANTITY REQUIRED	PART DESCRIPTION	PART NUMBER	
**	1	Main (Metering) Rotor Assembly	AAT-35	006-34-550-02
			AAT-57	006-44-550-02
**90	1	Carrier Assembly (Includes Illustration Nos. 90 A-J)	AAT-35	006-34-519-03
			AAT-57	006-44-519-03
90A	1	Coupling Shaft Shield Tube		006-34-082-01
90B	1	Oil Tubing, Aluminum		006-34-079-00
90C	2	Filter Screen, Stainless Steel		006-22-083-01
90D	2	Screen Retainer		904419
**90E	1	Bearing Bracket Carrier (Includes 90F, G & J)	AAT-35	006-34-019-04
			AAT-57	006-44-019-04
90F	6	#6-32 x 1/4" Pan Head Machine Screw		950585
90G	4	Module Seal Positioner		950755
90H	1	Pressure Tap Tube (AAT-35 Only)		006-34-079-02
90J	3	Vane Inserts		006-34-025-00
91	1	Bearing Bracket		006-34-209-00
**92	1	Rotor and Insert Assembly	AAT-35	006-34-350-02
			AAT-57	006-44-350-02
93	1	Main Rotor Shaft		006-34-024-02
94	1	Locking Pin, Rotor to Shaft		006-24-069-00
95	1	Spherical Washer		006-34-077-00
96	1	Locknut		906180
*97	1	Downstream Rotor Shaft Bearing		950236
98	1	Worm and Chopper Assembly (Includes 98A-C & 99)		006-34-308-03
98A	1	Worm		006-34-017-00
98B	1	Chopper Disc		006-34-108-03
98C	1	Retaining Ring		950800
99	2	Retaining Set Screw, Worm and Chopper Disc to Shaft Socket Head Stainless Steel, #4-40 x 1/8" Lg. Nylon Locking		950305
*100	1	Upstream Rotor Shaft Bearing		950277
101	1	Upstream Bearing Retainer Plate		006-34-117-00
102	3	Retainer Plate Screws, #3-48 x 3/16" Long Round Head Stainless Steel Machine Screw		903013
103	3	Retainer Plate Screws Lockwashers, #3 Stainless Steel		950372
104	1	Retaining Nut, Main Rotor Shaft		006-34-084-00
105	1	Wormwheel Shaft		006-24-046-20
106	1	Wormwheel (15T)		006-24-035-00
107	1	Wormwheel Hub		006-24-070-02
108	2	Wormwheel Hub Set Screw, #6-32 x 1/8" Long Stainless Steel Nylon Locking		950375
*109	2	Wormwheel Shaft Bearings		908660
110	2	Bearing Retainer Plate		006-22-117-01
111	4	Retainer Plate Screws, #4-40 x 1/4" Long Stainless Steel Machine Screw		950380
112	4	#4 External Lockwasher, Stainless Steel		950078
113	1	44T Gear	AAT-35	006-31-344-44
		49T Gear	AAT-57	006-44-344-49
114	1	Gear Set Screw, #6-32 x 1/8" Long Stainless Steel Nylon Locking		950375
115	1	29T Gear, Upshaft	AAT-35	006-34-329-29
		24T Gear, Upshaft	AAT-57	006-44-329-24
116	1	Gear Post		006-31-028-00
117	1	Gear Retainer		006-24-080-00
118	1	Gear Retainer Screws, #4-40 x 1/4" Long Stainless Steel		950380
119	1	Retainer Screw Lockwasher, #4, Stainless Steel		950078
120	1	Oil Reservoir Cover		006-34-053-01
121	1	Gasket, Oil Reservoir		006-34-160-00
122	1	Reservoir Cover Screw, #4-40 x 1/4" Long Stainless Steel		950380
123	1	Cover Screw Lockwasher, #4 Stainless Steel		950078
124	1	Oil Wick, .09" x .09"		1191430
125	1	Slot Sensor Holder		006-34-078-00
126	1	Slot Sensor Switch		006-34-134-00
127	1	#0-80 x 3/16" Long Flat Head Stainless Steel Machine Screw		950238
128	2	#5-40 x 1/16" Long Fillister Head Stainless Steel Machine Screw		950243
129	2	#5 Internal Lockwasher Stainless Steel		950374
130	1	Bearing Bracket Filter Screen Stainless Steel		006-22-083-01
131	1	Filter Screen Retainer		904419
*132	1	Bracket to Carrier "O" Ring, Buna		950102
133	4	Bracket Retaining Screws, #6-32 x 1/2" Long Round Head Stainless Steel Machine Screw		950373
134	4	Bracket Retaining Screw External Lockwasher, #6 Stainless Steel		950144
135	1	Seal, Oil Passage		006-35-160-09
136	1	Cable Clamp		950407

*Recommended Spare Parts

**These items affect calibration and must be ordered in combination with Sensor Assembly, (Center) Plate, and Internal Housing.

6" AAT-35 and AAT-57 AUTO-ADJUST® II TURBO-METER

SENSING ROTOR ASSEMBLY COMPONENTS

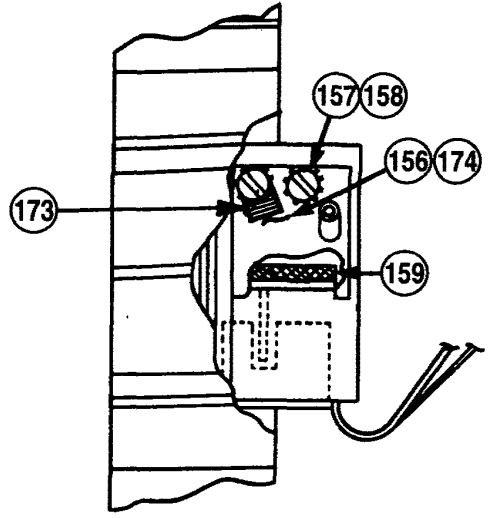
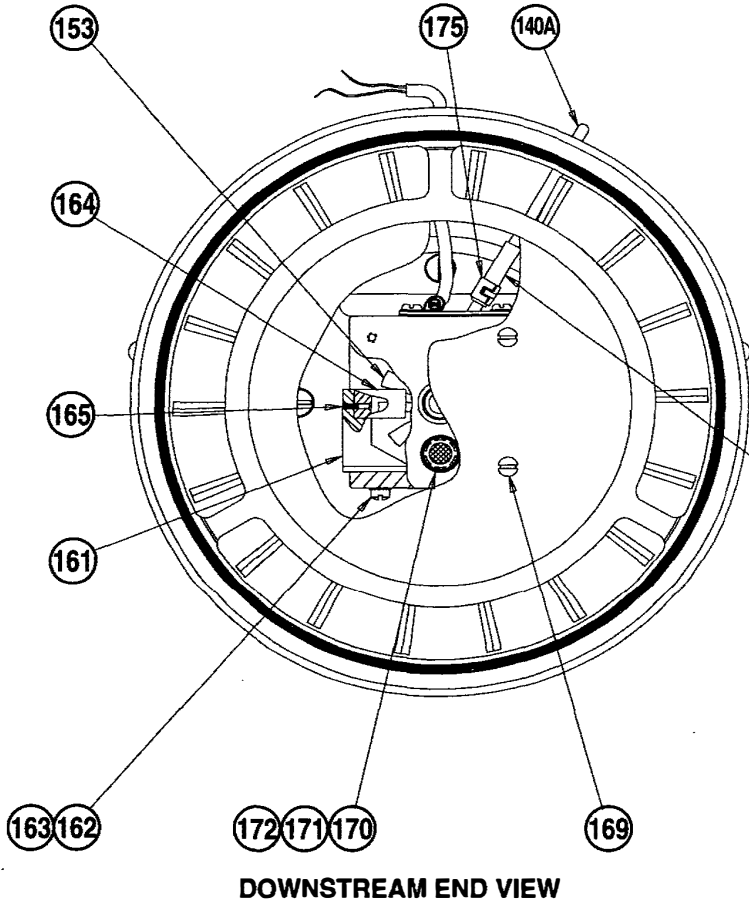

**BEARING BRACKET
TOP VIEW**

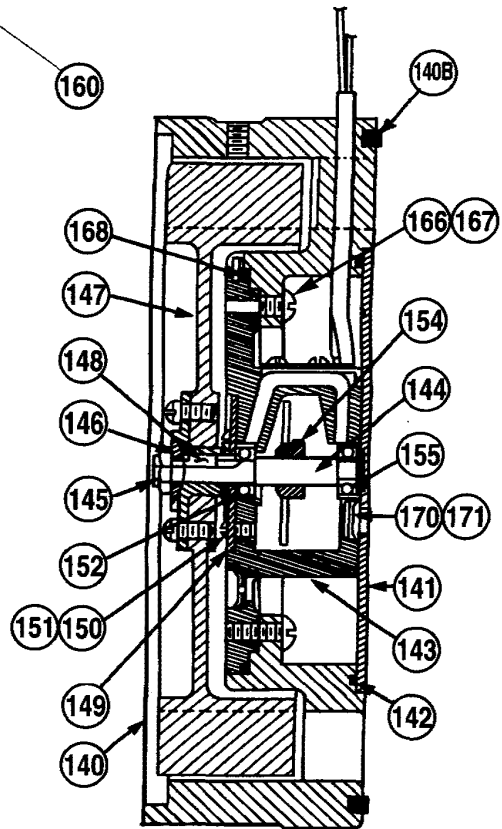

SIDE VIEW



Sensing Rotor Assembly Components

ILLUSTRATION NUMBER	QUANTITY REQUIRED	PART DESCRIPTION	PART NUMBER
**	1	Sensing Rotor Assembly (Buna)	AAT-35 006-34-550-03 AAT-57 006-44-550-03
** 140	1	Carrier Assembly (Includes Illustration Nos. 140 A & B) (Buna)	AAT-35 006-34-519-02 AAT-57 006-44-519-02
140A	1	Oil Tubing, Aluminum	006-34-079-01
140B	1	Module to Body Seal, Buna	950709
141	1	Housing Plate	006-34-010-00
*142	1	Carrier To Housing Plate Seal, Buna	950287
143	1	Bearing Bracket	006-34-221-00
144	1	Rotor Shaft, Stainless Steel	006-34-024-01
145	1	Locknut	906180
146	1	Spherical Washer	006-34-077-00
** 147	1	Rotor and Insert Assembly	AAT-35 006-34-350-01 AAT-57 006-44-350-01
148	1	Rotor Locking Pin	006-24-069-00
149	1	Upstream Bearing Retainer Plate	006-34-117-01
150	3	#2-56 x 1/4" Long Round Head Stainless Steel Machine Screw	950239
151	3	#2 Internal Lockwasher, Stainless Steel	904022
*152	1	Upstream Rotor Shaft Bearing	905435
153	1	Chopper Disc Assembly (Includes Illustration No. 154)	006-34-308-02
154	1	#4-40 x 1/8" Long Hexagonal Stainless Steel Set Screw, Nylon Locking	950305
* 155	1	Downstream Rotor Shaft Bearing	905435
156	1	Oil Reservoir Cover Assembly	006-34-253-00
157	4	Cover Retaining Screws, #4-40 x 1/4" Long Round Head Stainless Steel	950380
158	3	#4 External Lockwasher	950078
159	1	Oil Wick, .09" x .09"	1191430
160	AR	Tubing for Oiling System	99993
161	1	Slot Sensor Holder	006-34-078-00
162	2	Holder Retaining Screw, #5-40 x 7/16" Long Fillister Head	950243
163	2	#5 Internal Lockwasher, Stainless Steel	950374
164	1	Slot Sensor Switch Assembly	950563
165	1	Switch Retainer Screw, #0-80 x 1/16" Long Stainless Steel Machine Screw	950238
166	4	Carrier to Bracket Screw, #8-32 x 1/2" Long Round Head Stainless Steel Machine Screw	908722
167	4	#8 External Lockwasher, Stainless Steel	950371
* 168	1	Carrier to Bracket Seal, Buna	950285
169	4	Bracket Retaining Screws, #4-40 x 1/4" Long Fillister Head	903110
170	2	Filter Screen, Stainless Steel	006-22-083-01
171	2	Screen Retainer	904419
* 172	1	Bracket to Housing Plate Seal, Buna	950320
		Bracket to Housing Plate Seal, Viton	950480
173	1	Wire Clamp	950407
174	1	Gasket Oil Reservoir	006-34-160-01
175	1	Compression Ring	950682
176	AR	Oil, 4 oz. Bottle RFEM (Not Shown)	006-22-405-01
177	AR	Oil, 1 gal. Can (Not Shown)	006-22-405-02
178	AR	Lubrication Hand Gun (Not Shown)	006-24-400-00
179	AR	Blank Top Plate, 175# W.P. (Not Shown)	006-24-003-26
180	AR	Blank Top Plate, 275# W.P. (Not Shown)	006-24-003-27
181	AR	Blank Top Plate, 720/1440# (Not Shown)	006-24-003-92

*Recommended Spare Parts

**These items affect calibration and must be ordered in combination with Main Rotor Assembly, (Center) Plate, and Internal Housing.

SENSUS

6" AAT-35 and AAT-57 AUTO-ADJUST® II TURBO-METER

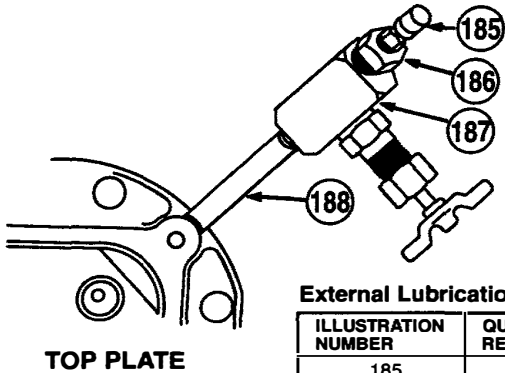

External Lubrication System Fittings

ILLUSTRATION NUMBER	QUANTITY REQUIRED	PART DESCRIPTION	PART NUMBER
185	1	Lubrication Gun Fitting, 1/8" NPT	907887
186	1	Hex Bushing, 1/4" to 1/8" Steel	950759
187	1	Valve, 1/4" Brass, #175 W.P.	950428
		Valve, 1/4" Carbon Steel, HP	950710
188	1	Nipple, 1/4" x 3" Brass, #175 W.P.	904765
		Pipe Nipple, 1/4" x 3" Steel, HP	950760

Electrical System Fittings

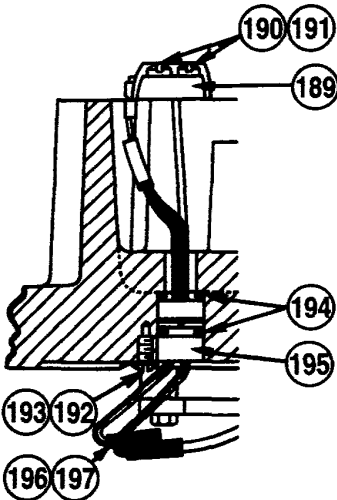
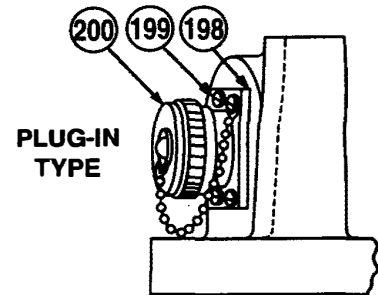
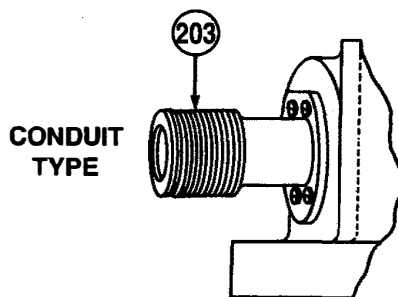

ILLUSTRATION NUMBER	QUANTITY REQUIRED	PART DESCRIPTION	PART NUMBER
189	1	Terminal Block	950364
190	3	#8-32 x 3/8" Long Fillister Head Stainless Steel Machine Screw	903371
191	4	External Lockwasher, #8, Stainless Steel	950371
192	1	#8-32 x 3/8" Long Fillister Head Stainless Steel Machine Screw	903371
193	1	Washer	950448
194	2	"O" Rings, Buna	946861
		"O" Rings, Viton	902418
195	1	Feed-Through Assembly	950588
		Feed-Through Assembly (Viton)	006-32-317-00
196	AR	Solder, Bar Form, 50/50, 1/4" dia., 2" pc.	750155
197	AR	Shrink Tube	800633



External Wiring Fittings

ILLUSTRATION NUMBER	QUANTITY REQUIRED	PART DESCRIPTION	PART NUMBER
198	1	Gasket	905321
199	4	#8-32 x 1/4" Long Round Head Stainless Steel Machine Screw	903055
200	1	Cap and Chain Assembly for Plug-In Connector	006-32-131-00
201	1	Plug-In Connector, Female End (Not Shown)	950388
202	1	Plug-In Connectors, Male End With Wiring to Terminal Block (Not Shown)	006-34-250-00
203	1	Conduit Adapter Assembly, 1/2"-14 NPT with Wiring to Terminal Block	006-34-330-00

WIRING SYSTEM COMPONENTS

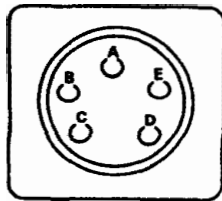
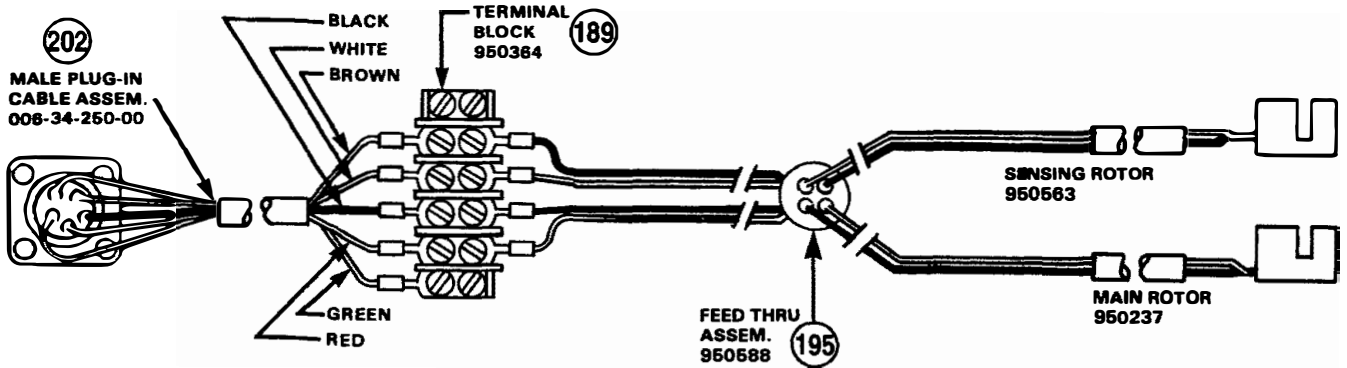

PLUG-IN CONNECTOR MALE END

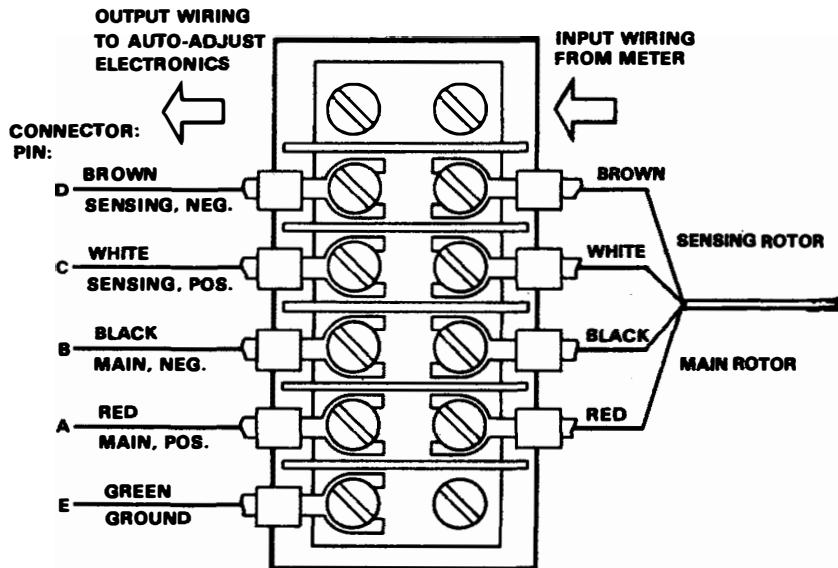

TERMINAL BLOCK WIRING DETAIL FOR PLUG-IN OR CONDUIT TYPE CONNECTORS



805 Liberty Boulevard
DuBois, PA 15801
814-375-8875
Fax 814-375-8460

Authorized Distributor

All products purchased and services performed are subject to Sensus' terms of sale, available at either; <http://na.sensus.com/TC/TermsConditions.pdf> or 1-800-METER-IT. Sensus reserves the right to modify these terms and conditions in its own discretion without notice to the customer.

This document is for informational purposes only, and SENSUS MAKES NO EXPRESS WARRANTIES IN THIS DOCUMENT. FURTHERMORE, THERE ARE NO IMPLIED WARRANTIES, INCLUDING WITHOUT LIMITATION, WARRANTIES AS TO FITNESS FOR A PARTICULAR PURPOSE AND MERCHANTABILITY. ANY USE OF THE PRODUCTS THAT IS NOT SPECIFICALLY PERMITTED HEREIN IS PROHIBITED.